



CUT OUT:

Vilene Pelmet with out seam allowance 1x #1, 1x #2, 2 x #3
(1cm seam allowance is included on pattern pieces 1, 2, and 3.)

Simply trim it off or print the pattern twice and cut on the dotted lines for these pieces)

Cut with seam allowance 1 x #3

Lining with seam allowance - 1 x #1, 1 x #2, 1 x #3

Fabric with seam allowance - 1 x #1, 1 x #2, 1 x #3

Straps and centre piece - cut one of each

PARTY BAG

Jeanne Spaziani page 118

Reproduce all templates at 250%

For a full size pattern template of the Party bag and the Twist top gift box visit www.craftsinstitute.com

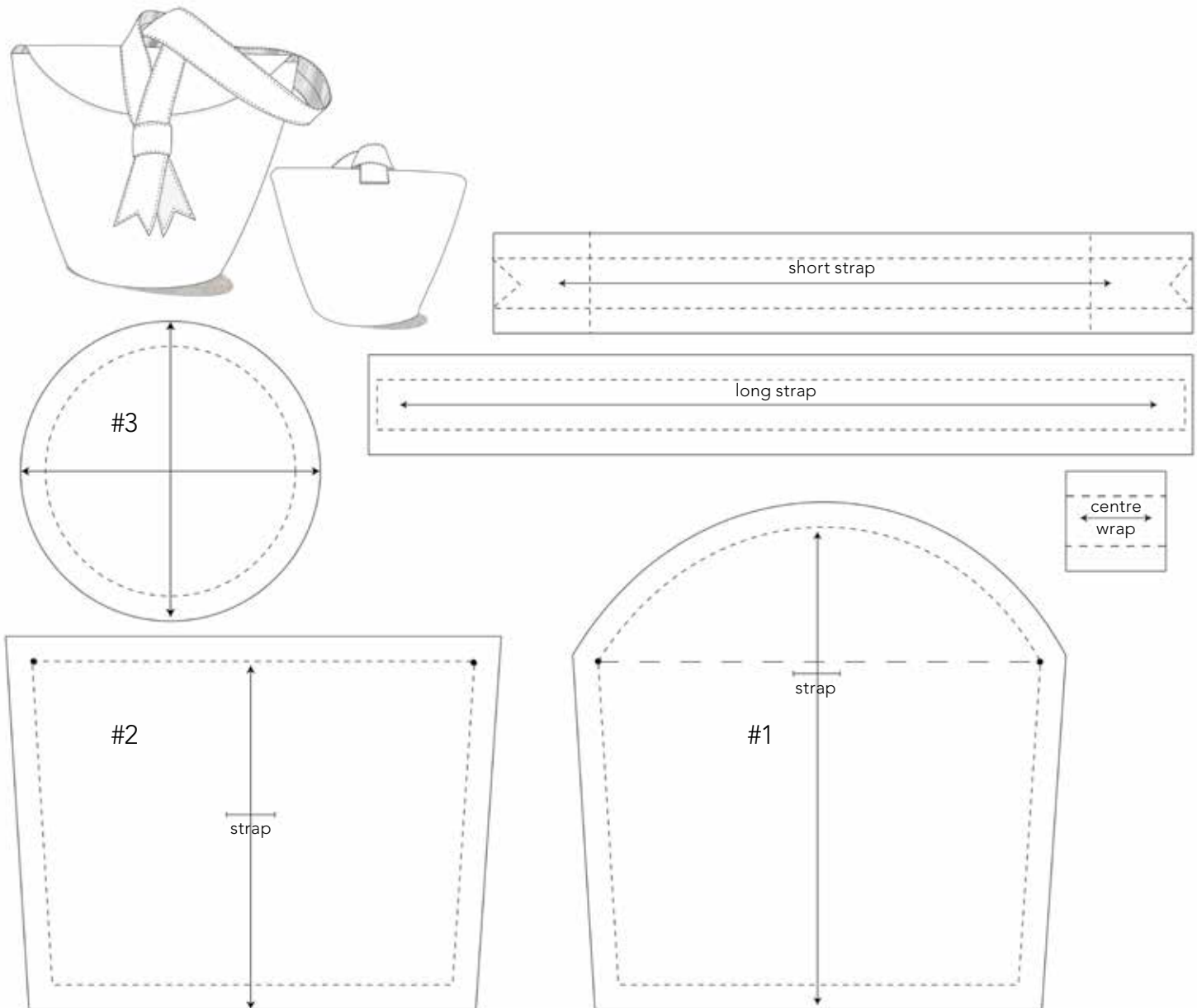

Party bag

Make a cute wrist bag to accessorise your party outfit. **By Jeanne Spaziani**

You will need

45cm x 45cm fabric (suede, brocade, taffeta, velvet, felt or wool are all great choices)
36cm x 45cm Vilene Pelmet or extra heavyweight sew-in interfacing
36cm x 45cm lining fabric
Craft glue
Sewing equipment
33cm x 12cm piece of Bondaweb
60cm of 1.5cm wide satin or grosgrain ribbon to line straps

1. From the printed out pattern pieces cut out the different material layers as instructed on the templates on page 143.

2. Begin constructing the Vilene interlining layer first. Lay piece 2 on top of piece 1. Attach the two sides together by stitching in only 2mm in from the cut edge. Turn through so the tiny seam allowance is facing in. Take the two circles that have also been cut without any seam allowances, lay one on top of the other and sew them together near the edge. Take the third circle that does have seam allowances and clip all the way around at regular intervals from the edge towards the dotted sewing line but no further – about 1cm is good.

3. You are next going to glue this clipped edge up inside the body of the bag to make the base. Smear some craft glue around the lower inside 1cm edge of the Vilene body. With your fingers pre-fold the clipped circle edge up along the 1cm in dotted line. With the bag body standing on a flat surface carefully begin pushing the clipped circle down into it, clip the seam allowance pointing up until it is sitting against the flat surface. With the fingers of one hand inside hold it down firmly and with the other hand press all around the glued area to make sure the join is secure. Let it dry for a bit. Smear some glue on one side of the stitched together double circle and push that down

into the bottom of the bag so it sticks to the first circle as well. While you're waiting for that to dry make the lining and the outside of the bag. This bag is made in suede, if you choose a woven fabric instead just keep an eye out for fraying edges.

4. Making the outer layer: sew pieces 1 and 2 together from the lower cut edge sewing up to the top edge dots marked on the pattern but no further. Back-tack so the top stitches are secure. Press the side seams open. An edge stitch on either side of the seam will keep them in place and gives a nice finish too.

5. With right sides together pin and sew piece 3 into its position as the base. After sewing, it is a good idea to trim this seam as close to the stitches as your material will allow so it won't make the base lumpy. Using suede I could trim it to 3 millimetres but if you are using a fabric that frays a bit cutting V notches may be preferable.

6. Turn the outer fabric right side out and carefully slide the Vilene layer in. As it nears the base try to keep the fabric seam allowances laying in towards the centre of the base rather than up the sides as your bag will have smooth sides that way. The outer fabric should sit smoothly and snugly over the Vilene interlining without any buckling or distorting of the Vilene. Fold and pin the outer fabric over the Vilene edges of the flap and top of the bag. The flap curves will need some notches cut out to get the fabric to lay flat. Lightly hand tack the edges down onto the Vilene being careful that no stitches show on the right side of the bag.

7. To make the straps: cut your Bondaweb into 2cm wide strips, one

for each strap and the little centre wrap piece too. Iron a strip (see manufacturer instructions) down the centre of each strap. Peel off the paper, fold the outer 1cm of each strap over so they meet in the centre and iron in place so the Bondaweb holds firm. I also edge stitched my suede straps to give them a firm edge. The ribbon is now used to give the straps a nice finish: cut strips of Bondaweb the width of your ribbon and attach the ribbon to the inside of the strap. The longer strap is attached on piece 1 as marked on the pattern – simply machine topstitch it in place through both the outer and Vilene layers.

8. For the shorter strap cross the ends one over the other as illustrated and stitch across to hold. Wrap the centre piece over the stitching to hide it and hand sew behind to hold it in place. Then this whole piece is carefully hand sewn from the inside of the bag in place on piece 2 (as it is very awkward to get under the sewing machine).

9. Sew the lining together as in step 6 for the outer fabric. Press the 1cm seam allowances to the wrong side of the lining and wrong side out. Place it inside your bag. Pin and hand slip stitch the lining in place close to the edges around the flap and front edge.

Resources

Vilene Pelmet interfacing:
www.candh.co.uk

Tips

1. To stop edges from fraying as you work use a product like Fray Check or simply paint some diluted PVA glue on the area with a small brush and allow to dry before trimming.
2. Scale the pattern up to make a bigger bag – with a wipe-clean lining it would make a chic grown-up lunch bag.
3. To up the glam quota attach a sparkly pin or gorgeous fabric flower to the centre wrap in the front.

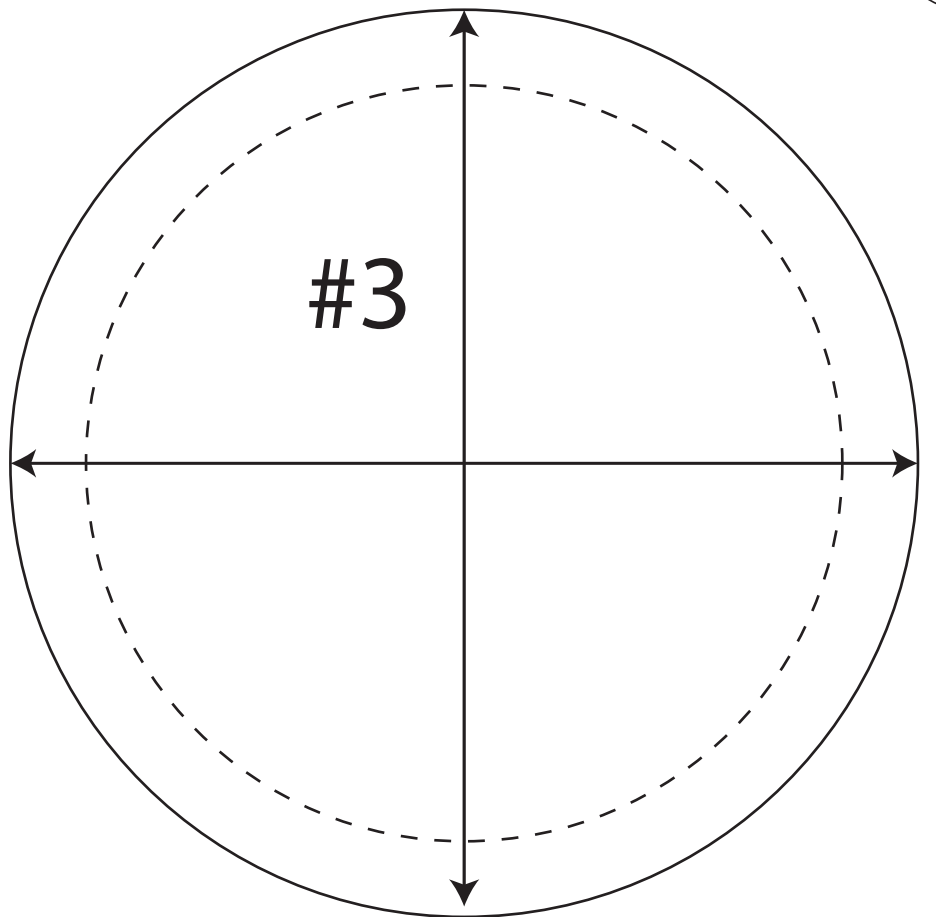
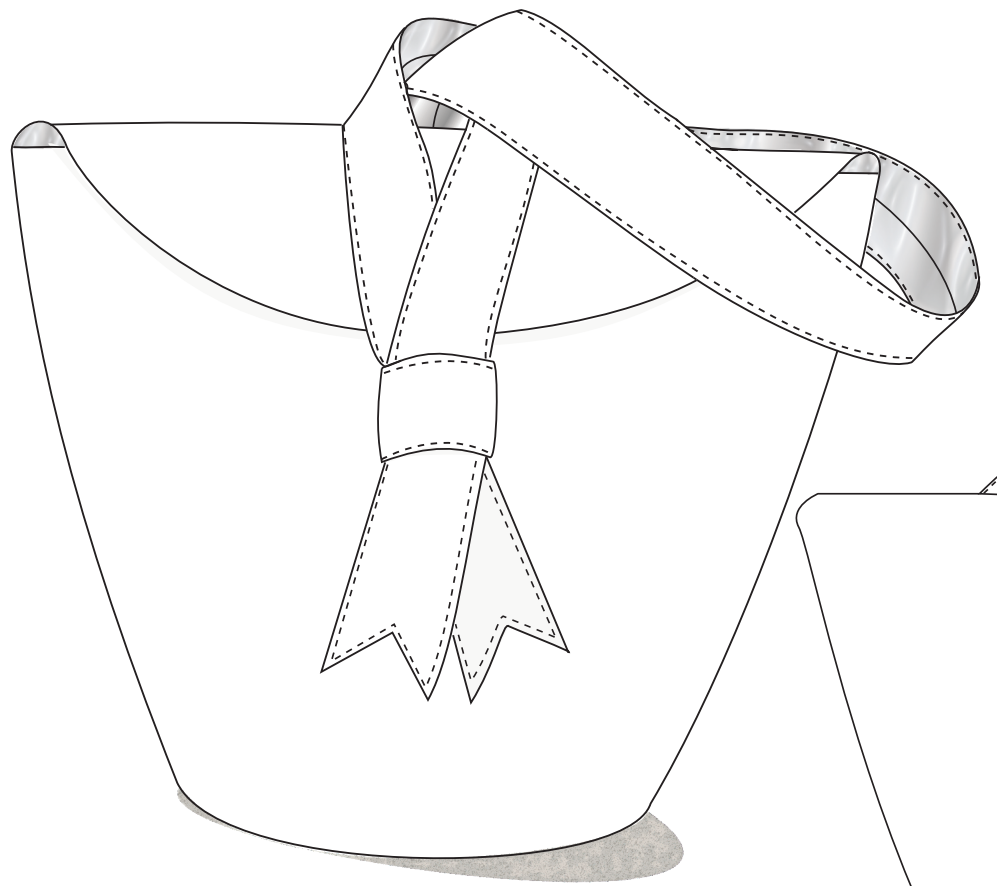

CUT OUT:

Vilene Pelmet with out seam allowance 1x #1, 1x #2, 2x #3 (1 cent
Simply trim it off o
cut with seam allowance 1x #3

Lining with seam allowance - 1x #1, 1x #2, 1x #3

Fabric with seam allowance- 1x #1, 1x #2, 1x #3

Straps and centre piece - cut one of each.

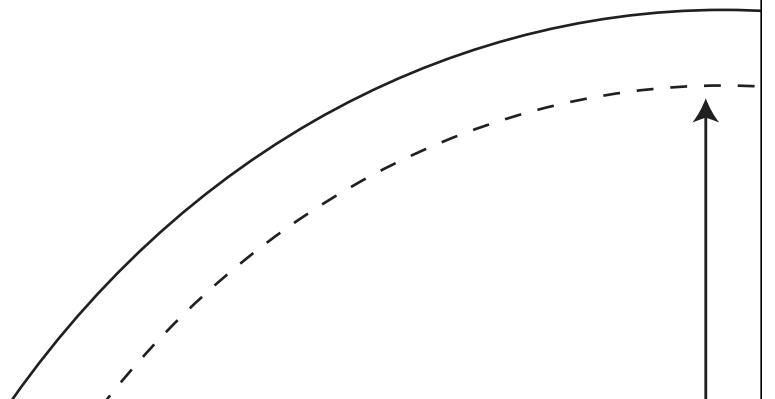
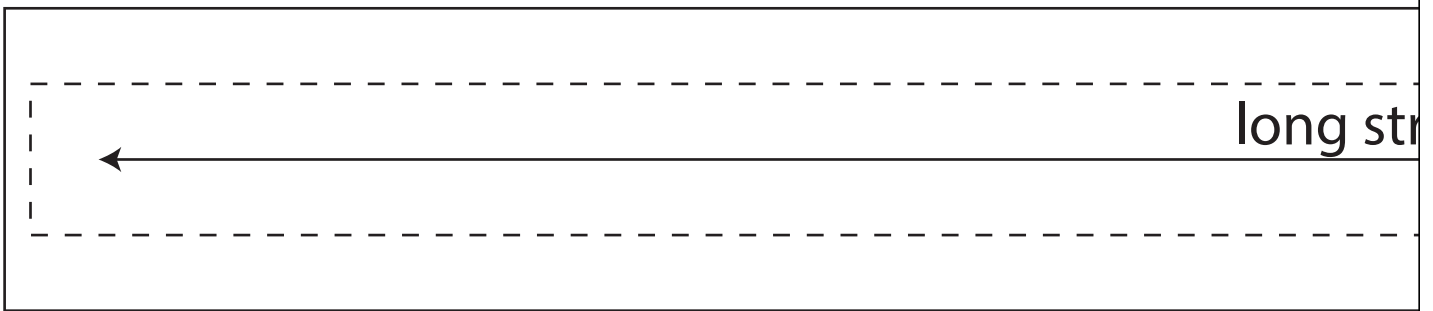
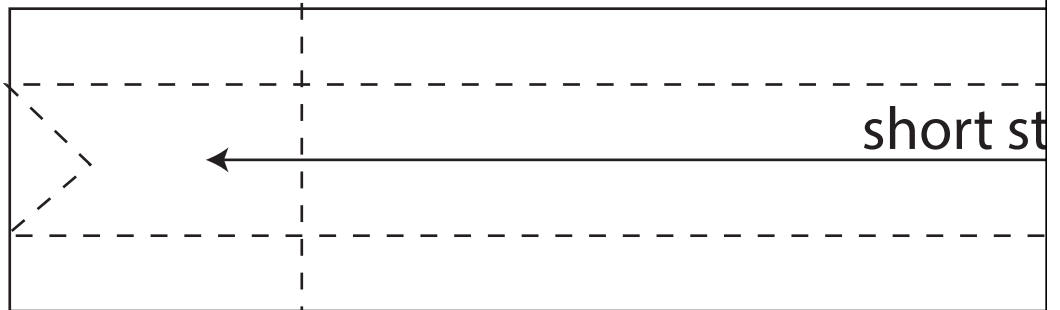
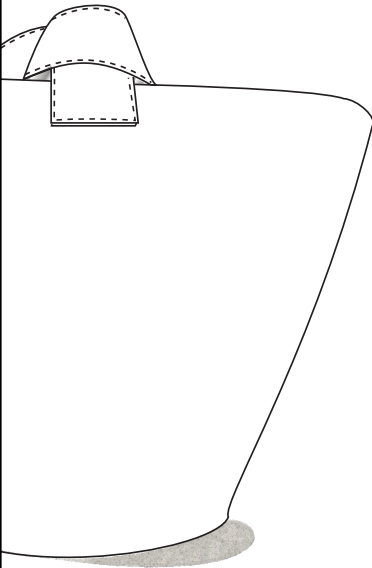

1 centimetre seam allowance is included on pattern pieces 1, 2, & 3.
(For print the pattern twice and cut on the dotted lines for these pieces)

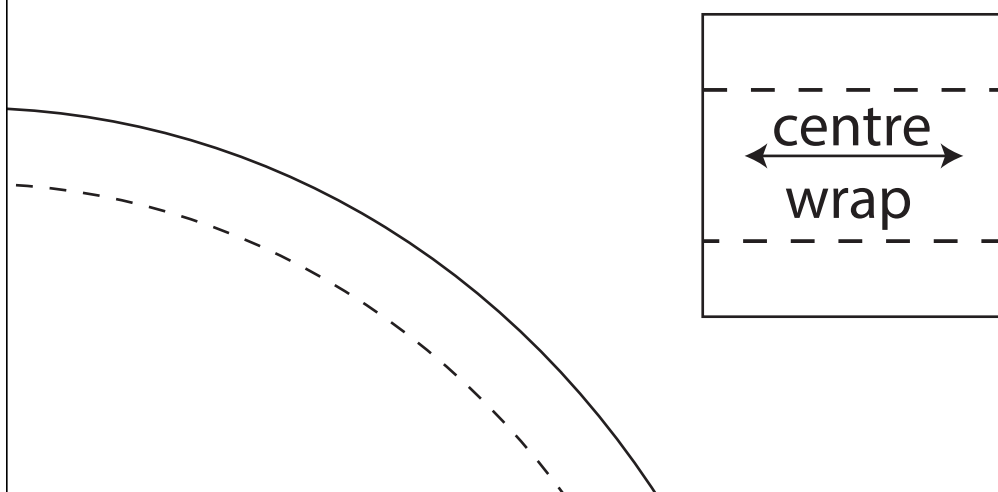
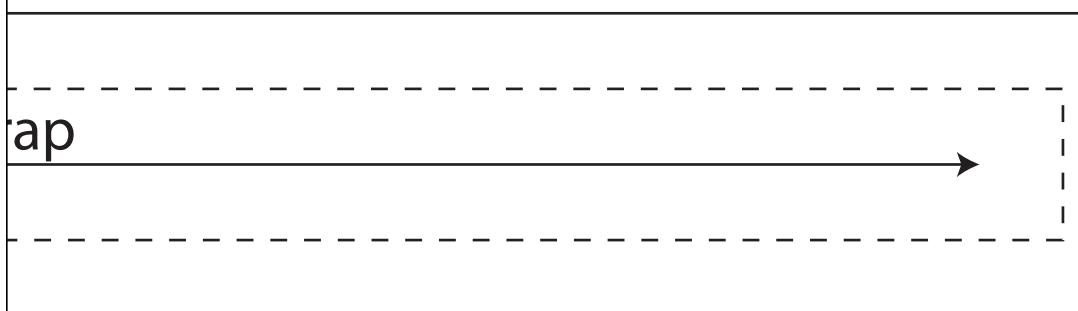
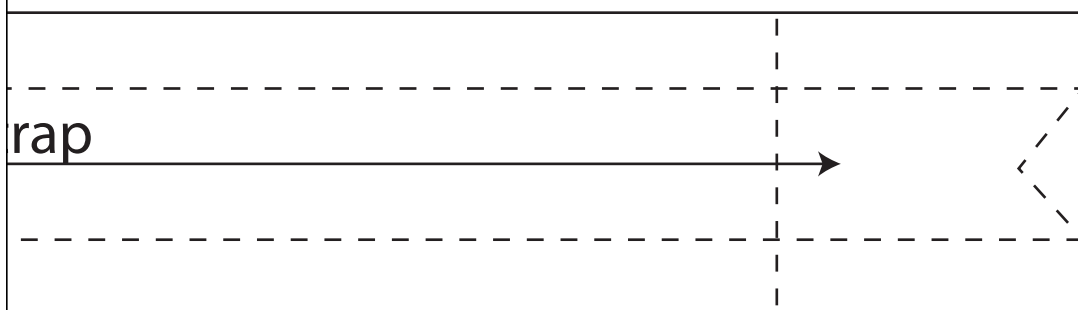

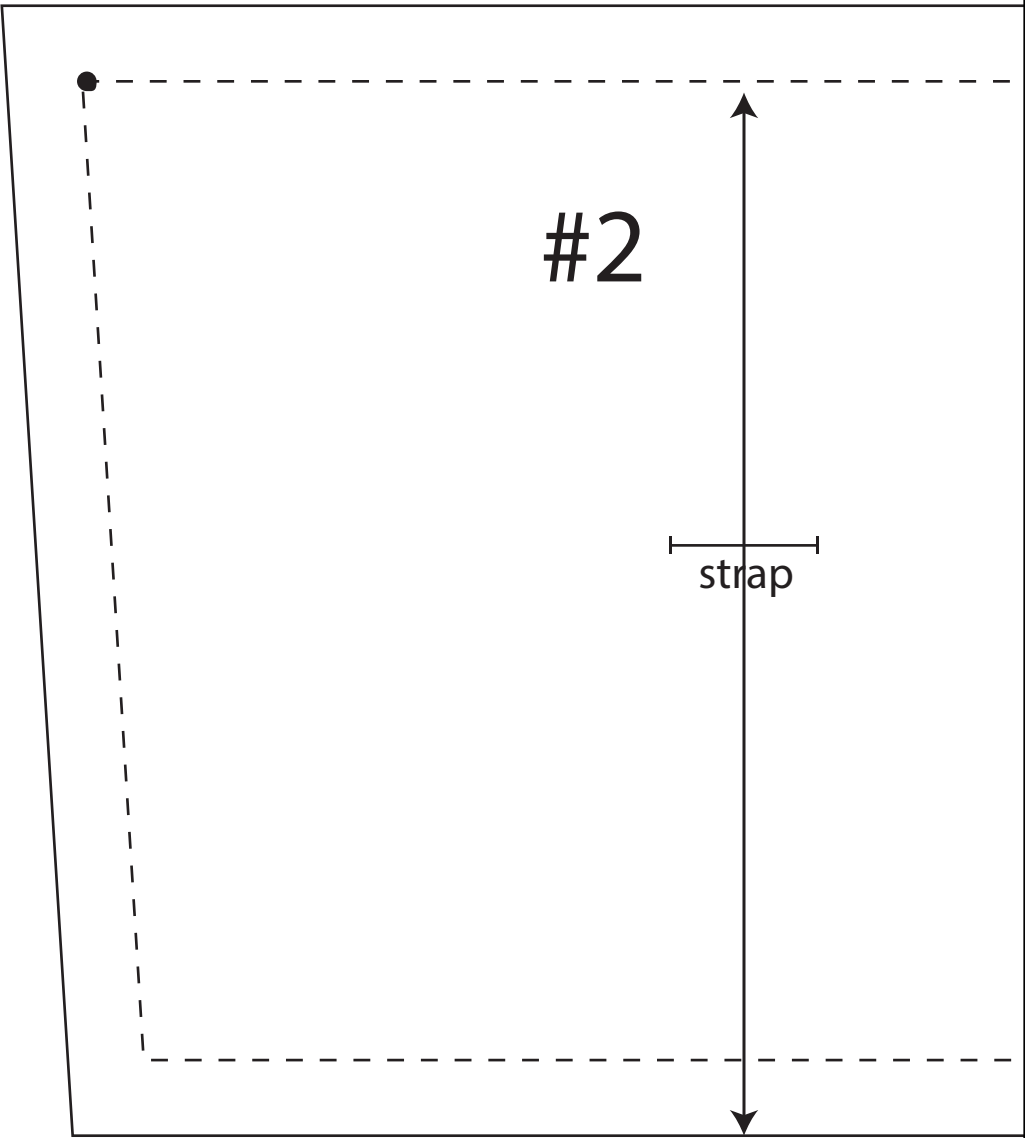

#2

strap

